

Specifications

| Model | | ST460 | |
|------------------------------------|--|--|------------|
| Transmission | | SSS | EHSS |
| Engine | | Shibaura N844LT-D | |
| Gross hp | | 60(44.7) | |
| PTO hp | | 51(38.0) | 50(37.3) |
| Number of cylinder | | 4 | |
| Displacement | | 2216 with Turbo | |
| Rated rpm | | 2800 | |
| Alternator | | 55 | |
| Fuel tank capacity | | 54 | |
| Drive train | | 24x24 | |
| Range | | 3 | |
| Creeper | | STD | |
| Ground speeds @engine 2950rpm | | Forward km/h | 0.18-31.34 |
| | | Reverse km/h | 0.20-33.28 |
| Brakes | | Wet Disc | |
| PTO Rear PTO RPM @rated engine rpm | | rpm 611 & 862 (540@2475rpm, 750@2438rpm) | |
| Pump capacity @rated engine rpm | | ℓ /min 66.3 | |
| - P/S Pump capacity | | ℓ /min 20.8 | |
| 3-P lift capacity @ lift hitch | | kg 1975 | |
| 3-P lift capacity @24 behind LP | | kg 1570 | |
| 3-P hitch category | | I & II | |
| Hydraulic position control system | | STD | |
| Hydraulic draft control system | | STD | |
| Steering system | | Power steering | |
| Tire size | | Ag | |
| | | Front | 9.5-16 |
| | | Rear | 14.9-28 |
| | | Turf | 27x10.5-15 |
| | | Rear | 475/65D20 |
| Weight | | Ag kg | 1905 |
| | | Turf kg | 1820 |
| | | | 1920 |
| | | | 1835 |

TRACTOR ST460

SHIBAURA



Dimensions(Ag tire)

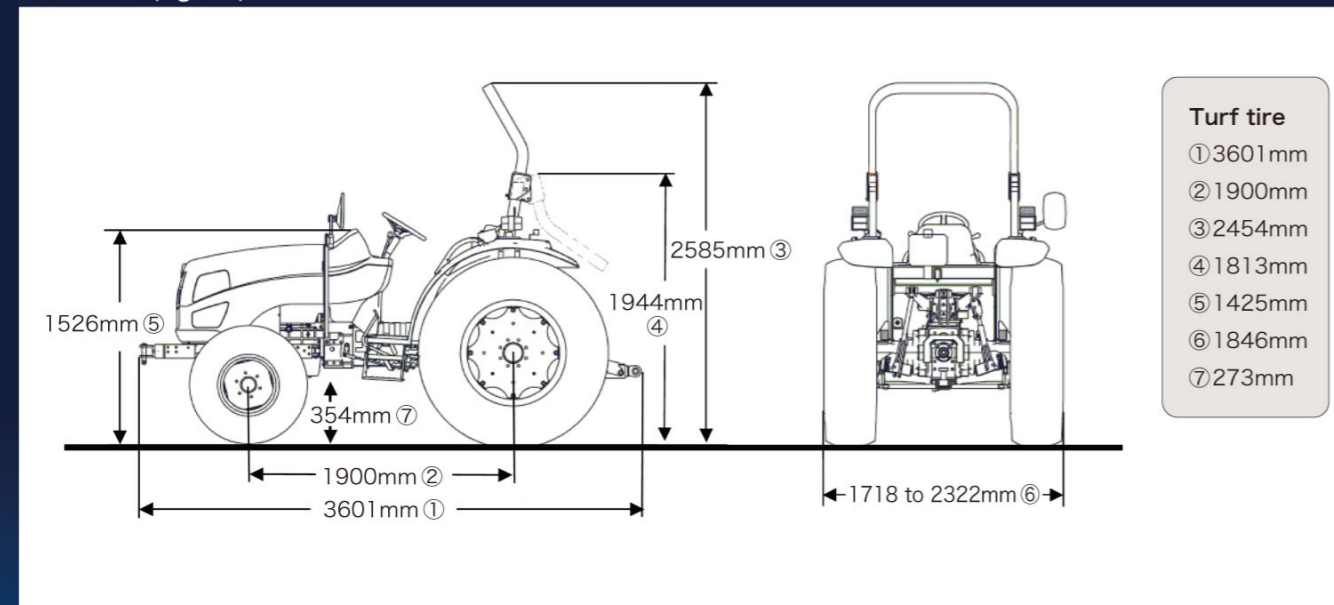

Important information Improper use of any product may cause serious or fatal injury. Read carefully the operating and safety instructions in your owner's manual before use.

※We reserve the right to discontinue models or change specifications without notice.



IHI Shibaura Machinery Corporation

BYGS Shinjuku Bldg., 2-19-1 Shinjuku,
Shinjuku-ku, Tokyo, 160-0022, Japan
TEL+81-(3)-5312-9662 FAX+81-(3)-5312-9668
GENERAL CONTACT - dept2@ism.ihi.co.jp
URL:www.ihi-shibaura.com/english

INT-TR-ST5-1104-20

Explore the Engineering Edge



IHI Shibaura Machinery Corporation

Uncompromising Powerful Performance

Shibaura's new 60hp tractor offers the stunning powerful performance to tackle an array of task.



Driver's comfort

The tiltable and telescopic steering column, and the suspension seat offer comfortable working condition.



PTO Control Switches

You can select Transmission PTO and Independent PTO to suit your work condition.



Shibaura technology Engine

It meets the EPA's Interim Tier 4 regulations.



EHSS (Electro Hydro Shuttle Shift) transmission

The Electro-hydraulic clutch system provides easy forward/reverse shifting, without clutching operation with the pedal.



CAT I & II three-point hitch

An interchangeable Category I and II three-point hitch permits variety of implements to be fit.

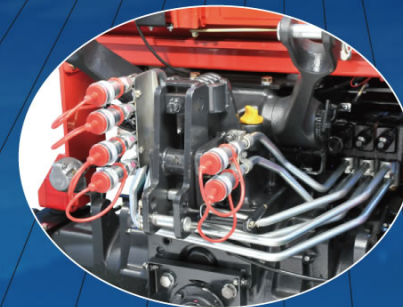

3-PAIR REMOTE CONTROL VALVES (Dealer Option)

Two circuits feature single/double-acting, and the one is single-acting with detent. A wide variety of hydraulically actuated and hydraulically driven implements can be used.

